

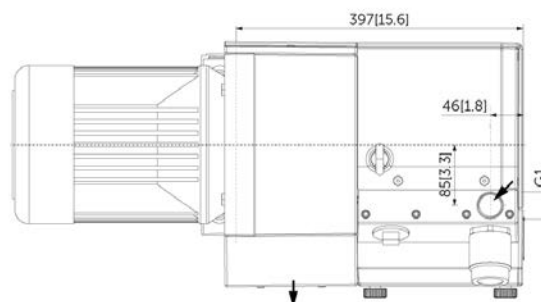

Model: **KVT3.80**

## SPECIFICATIONS

Volume flow 50 Hz	67 m <sup>3</sup> /h
Vacuum absolute 50 Hz	100 mbar
Power 50 Hz	2.2 kW
Noise Level 50 Hz	72.0 dB(A)
Volume flow 60 Hz	78.5 m <sup>3</sup> /h
Vacuum absolute 60 Hz	100 mbar
Power 60 Hz	2.6 kW
Noise Level 60 Hz	75.0 dB(A)
Weight	49 kg without motor

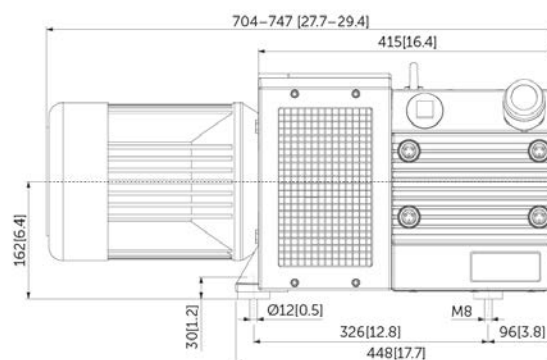
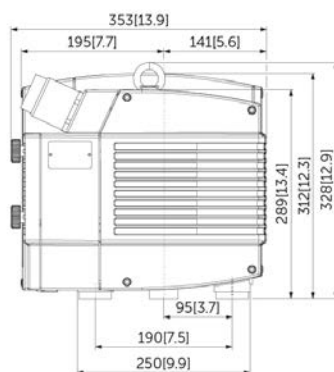

mm [inch]

BECKER KVT 3.80